

Chapter 4

Phylogenetic Trees

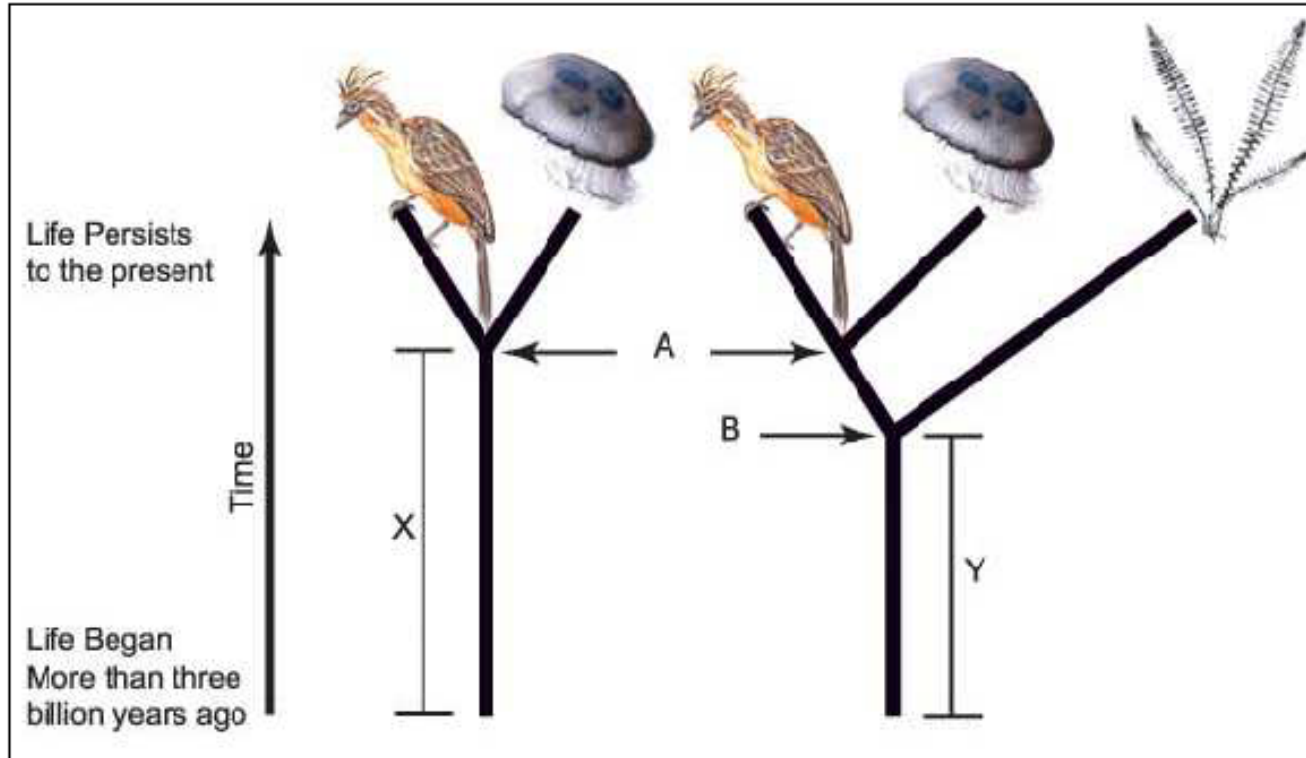

Figure 8.1 in R. Shamir, Orly Stettiner, R. Gabor: Algorithms for Molecular Biology 8.1 Preface: Phylogenetics and Phylogenetic Trees

- A: most recent common ancestor of bird and jellyfish
- X: portion of history shared by bird and jellyfish

What is Phylogenetics?

- Find the **evolutionary relationships** between species.
- **Basic idea**: compare specific features of the species.
Assumption: similar species are genetically close.
- The term **phylogeny** refers to these relationships, usually presented as a **phylogenetic tree**.
- Classic phylogeny: **physical or morphological features** – size, color, shape, number of legs, ...
- **Modern phylogeny** uses information extracted from genetic material – mainly **DNA and protein sequences**.
Features (characters): DNA or protein sites within **conserved blocks of multiple alignments**.

The Tree of Life

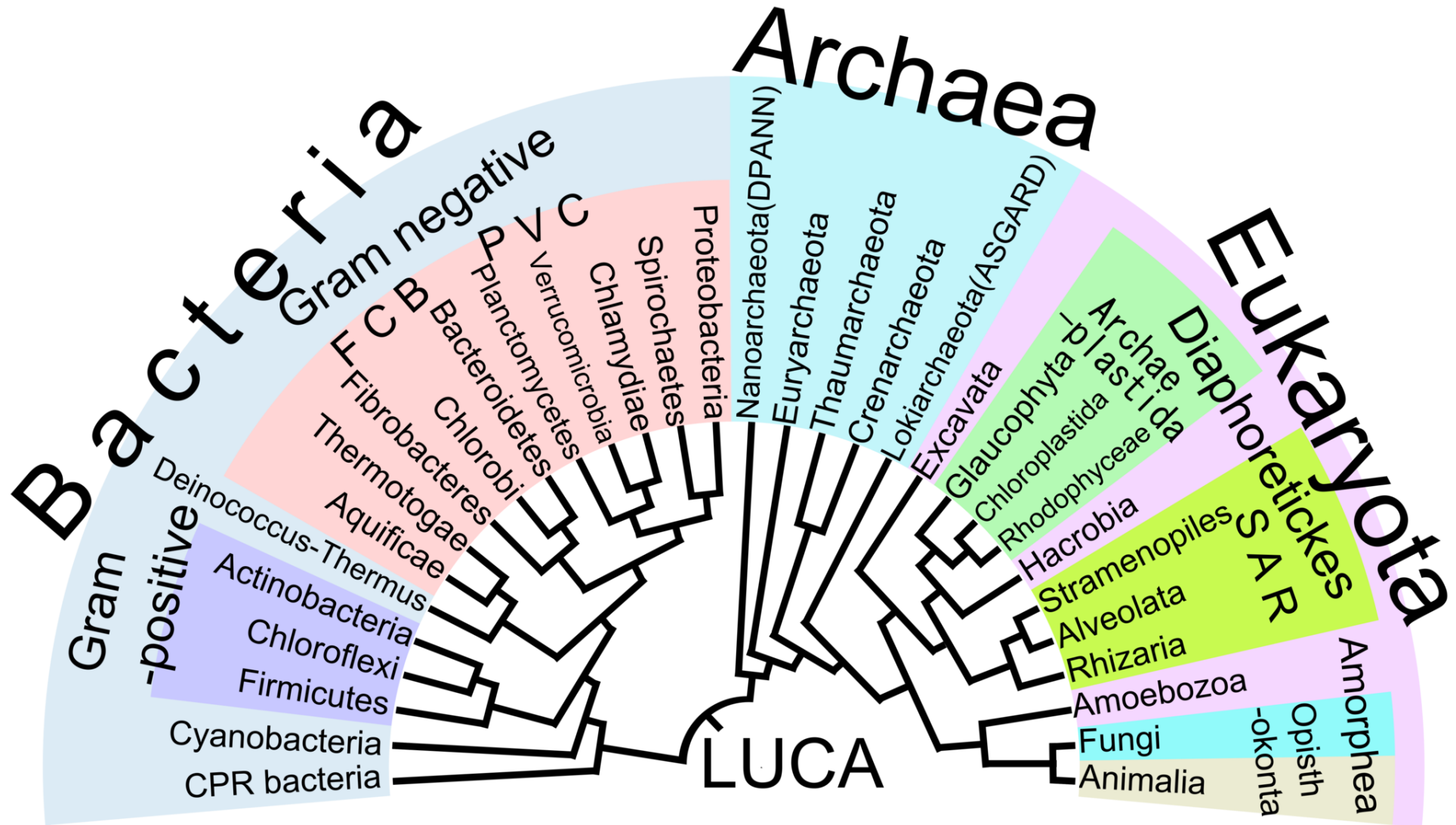

LUCA: Last universal common ancestor: the most recent common ancestor of all current life on Earth.

User:Crion / CC BY (<https://creativecommons.org/licenses/by/3.0>)

https://commons.wikimedia.org/wiki/File:Phylogenetic_Tree_of_Life.png

Approaches To Phylogenetic Tree Construction

Distance based methods:

require definition of a **distance function between objects**.

Construct tree so that the pairwise distances can be mapped to the tree **as accurately as possible**.

Character based methods:

character or **trait** = a discrete property of an object. E.g.

- “mammal” (all animals are either mammals or not)
- “unicellular” (either unicellular or multicellular)

Species are grouped according to similarity of characters.

Probabilistic methods:

Classification may be based on the **likelihood** of a certain tree explaining the set of objects.

Alternative: **Bayesian approach**. Combine likelihood with prior over trees \rightsquigarrow posterior distribution of trees.

Phylogenetic Trees

- Phylogenetic information usually represented as a **tree**:
 - every node represents a species,
 - edges represent the genetic connections.
- Difference between leaf nodes \rightsquigarrow **real species**,
and internal nodes \rightsquigarrow **hypothetical evolutionary ancestors**.
- **Phylogenetic trees** take several forms:
 - **rooted** \rightsquigarrow one of the nodes is the root
 \rightsquigarrow **direction of ancestral relationships is determined**,
 - **unrooted** \rightsquigarrow induces no hierarchy,
 - **binary** (or bifurcating) \rightsquigarrow a node has only 0 to 2 subnodes,
 - general (not covered here).

A Simple Solution?

Trivial solution: enumerate over all possible trees and calculate the target function for each one.

Problem: number of non-isomorphic, labeled, binary, rooted trees containing n leaves, is super-exponential:

$$(2n - 3)!! = \prod_{i=2}^n (2i - 3) = 1 \cdot 3 \cdot 5 \cdot 7 \cdots (2n - 3)$$

(or $(2n - 5)!!$ for unrooted trees). For $n = 20$: about 10^{21} trees
→ infeasible even for a relatively small number of species.

Theorem: Phylogenetic Tree Construction (for almost all reasonable models) is NP-Complete.

Number of nodes and edges

- Suppose there are n leaves in a **rooted tree**. As we move up the tree, two edges join as a new node is reached. Each time, the number of edges is reduced by one.
- So there must be $(n - 1)$ inner nodes $\rightsquigarrow (2n - 1)$ nodes and $(2n - 2)$ edges (not counting the edge above the root)

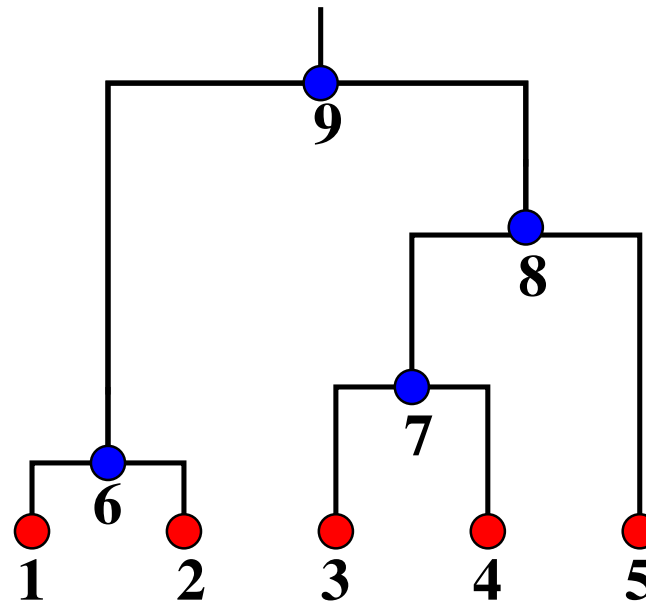

- **Unrooted tree:** $(2n - 2)$ nodes and $(2n - 3)$ edges.

Consider an **unrooted tree with n leaf nodes:**

- An **extra edge** with new label at its leaf can be added at any edge
 \rightsquigarrow there are $(2n - 3)$ times as many trees with $n + 1$ leaves.
- Instead of an extra edge, we can **add a root**
 \rightsquigarrow there are $(2n - 3)$ times as many rooted trees as unrooted ones.
- There are $1 \cdot 3 \cdot 5 \cdot \dots \cdot (2n - 5) = (2n - 5)!!$ unrooted trees with n leaves
 $\rightsquigarrow (2n - 3)!!$ rooted trees.

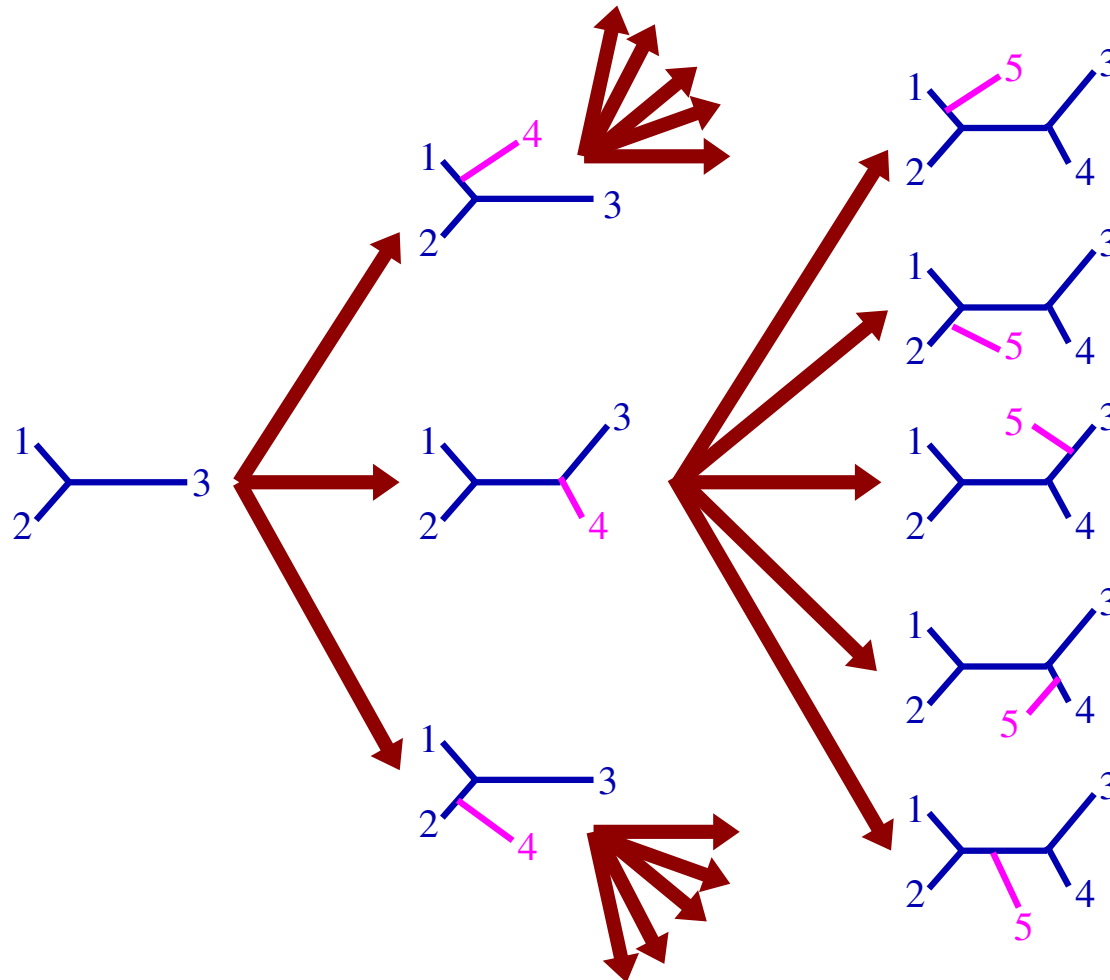

Distance-Based Methods

- Assume we have a **measure of distance** between each pair of species.
- **Approach:** find a tree that predicts the observed set of distances as closely as possible.
- This **leaves out some of the information** contained in the raw sequence (due to reduction to table of pairwise distances).
- It seems that in many cases **most of the evolutionary information** is conveyed in these distances.

Least Squares Methods

- **Idea:** approximate an observed distance matrix.
- **Goal:** find a tree T , whose leaves are the n given species, and that predicts distances d_{ij}^T between the species, so that the following expression is minimized:

$$SSQ(T) \equiv \sum_{i=1}^n \sum_{j \neq i} (d_{ij} - d_{ij}^T)^2$$

where d_{ij} is the observed distance between species i and j .

- SSQ is a measure of the discrepancy between the **observed distances d_{ij}** and the **path distances d_{ij}^T in the tree T** .

The Least Squares Tree Problem

Problem: Least Squares Tree.

INPUT: The distance d_{ij} between species i and j , for each $1 \leq i, j \leq n$, arranged in distance matrix D .

QUESTION: Find the phylogenetic tree T , with the species as its leaves, that minimizes $SSQ(T)$.

- Difficult problem, due to optimization over discrete set of topologies. One can show: NP-complete problem.
- Two polynomial heuristics - *UPGMA* and *Neighbor-Joining*. These are efficient algorithms, but they will only work in some particular cases.

Ultrametric trees: All the leaves have the same distance to the root \rightsquigarrow all species evolve at the same rate.

In such cases, UPGMA will find the correct topology.

Efficiently solvable Special Cases

Additive distance matrices: There exists a tree that represents **exactly** the given distances between species:

$d_{ij} = \sum$ of all edge lengths in the path between leaves i and j .

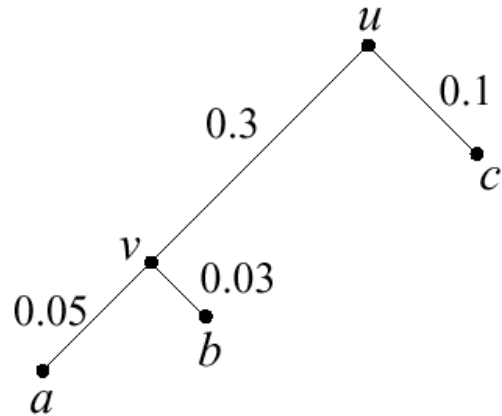

	a	b	c
a	0	0.08	0.45
b	0.08	0	0.43
c	0.45	0.43	0

In such cases, neighbor joining will find the correct topology.

In general, given a set of pairwise distances (\rightsquigarrow scales **quadratically** in n) it is not possible to find a set of internal edges (\rightsquigarrow number is **linear** in n) that explain all the observed distances as path distances in the tree.

UPGMA

- **UPGMA**, or *Unweighted Pair Group Method with Arithmetic mean*, is a heuristic algorithm that often generates satisfactory results.
- The algorithm iteratively **joins the two nearest clusters** (or groups of species), until one cluster is left.

Initialization:

1. Initialize n clusters C_i , one species per cluster.
2. Set the size of each cluster to 1: $n_i \leftarrow 1$.
3. In the output tree T , assign a leaf for each species.

Iteration:

1. Find the i and j that have the smallest distance d_{ij} .
2. Create a new cluster - k by $C_k = C_i \cup C_j$ and compute the distance from the new cluster to all other clusters as a weighted average of the distances from its components:

$$d_{kl} = \left(\frac{n_i}{n_i + n_j}\right)d_{il} + \left(\frac{n_j}{n_i + n_j}\right)d_{jl}.$$

3. Connect i and j on the tree to the new node k , and place it at height $d_{ij}/2$. Note: vertical axis represents time. Horizontal connections do not contribute to path-length computations.
4. Delete the columns and rows in D that correspond to clusters i and j , and add a column and row for cluster k .
5. Return to 1 until there is only one cluster left.

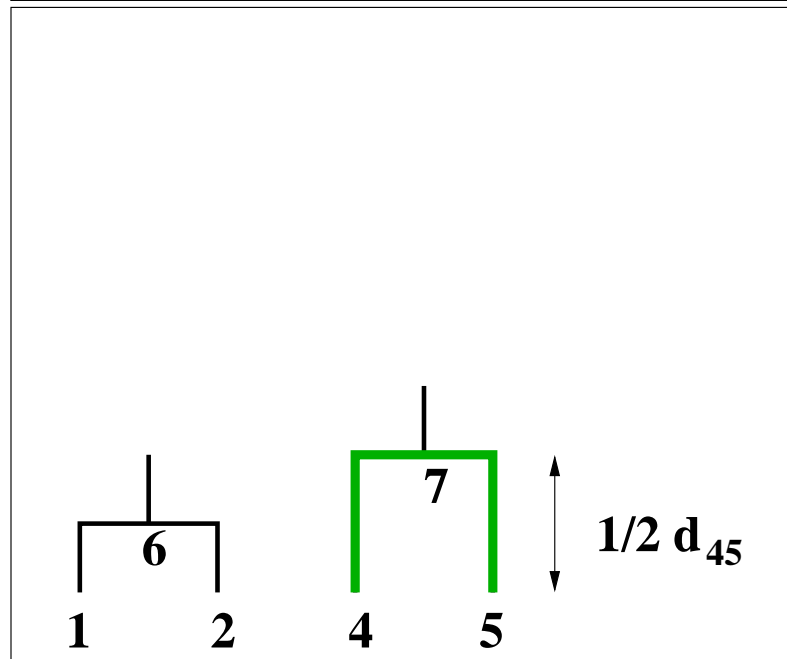
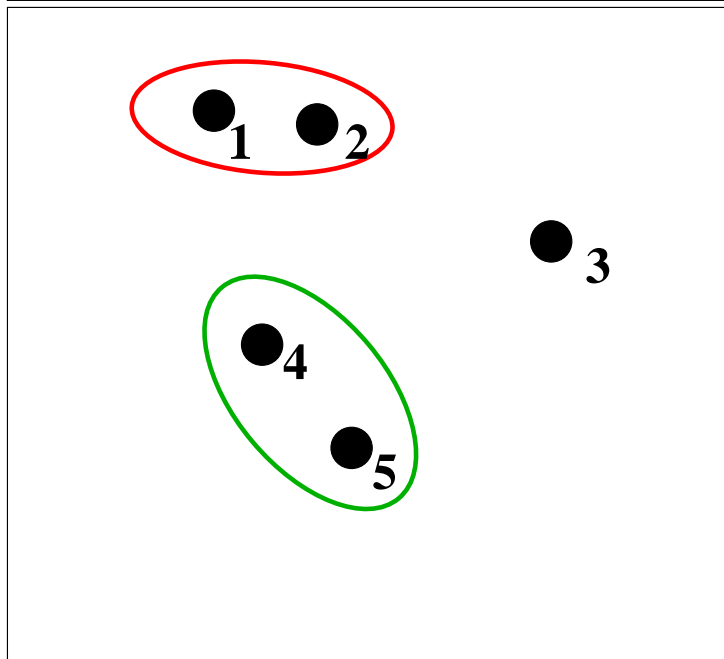
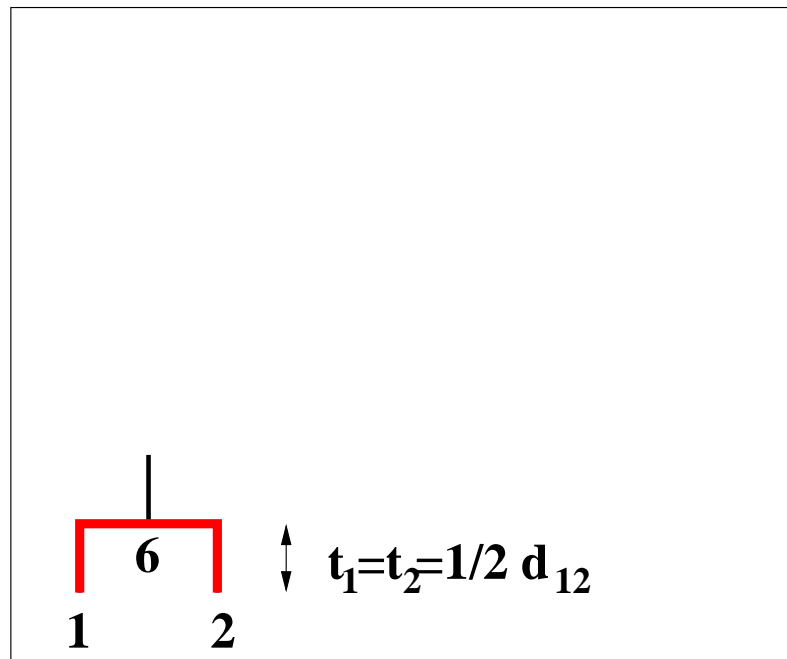
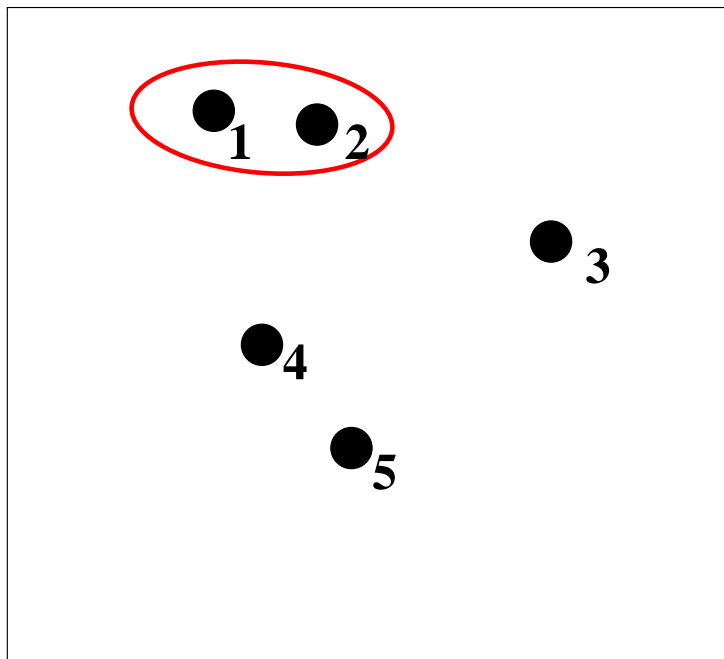

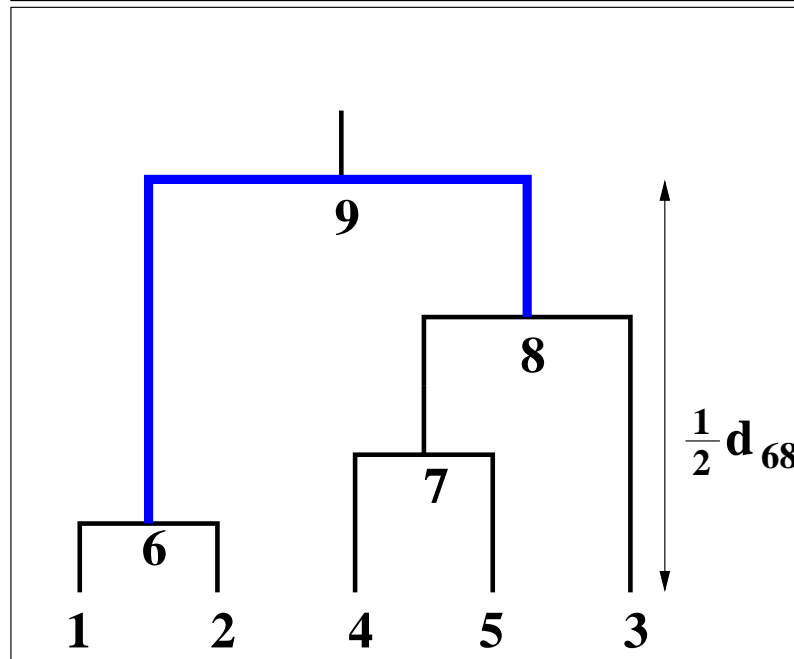
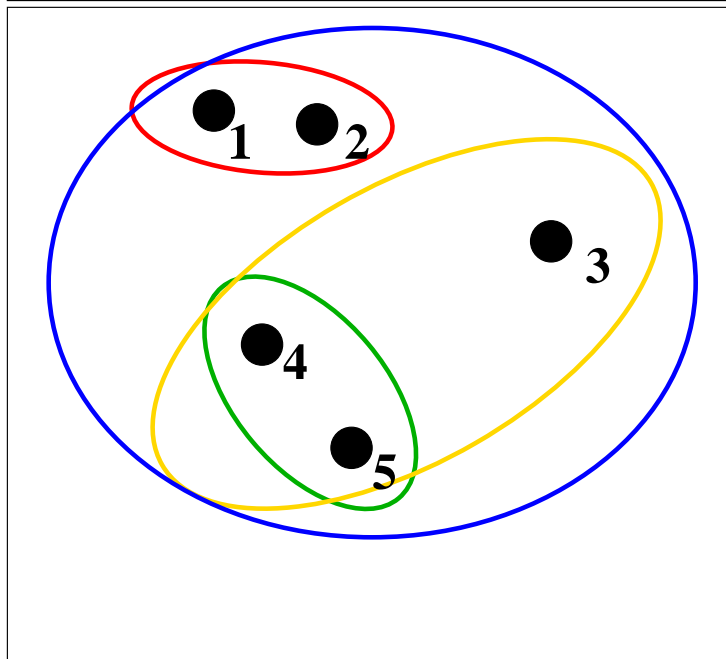
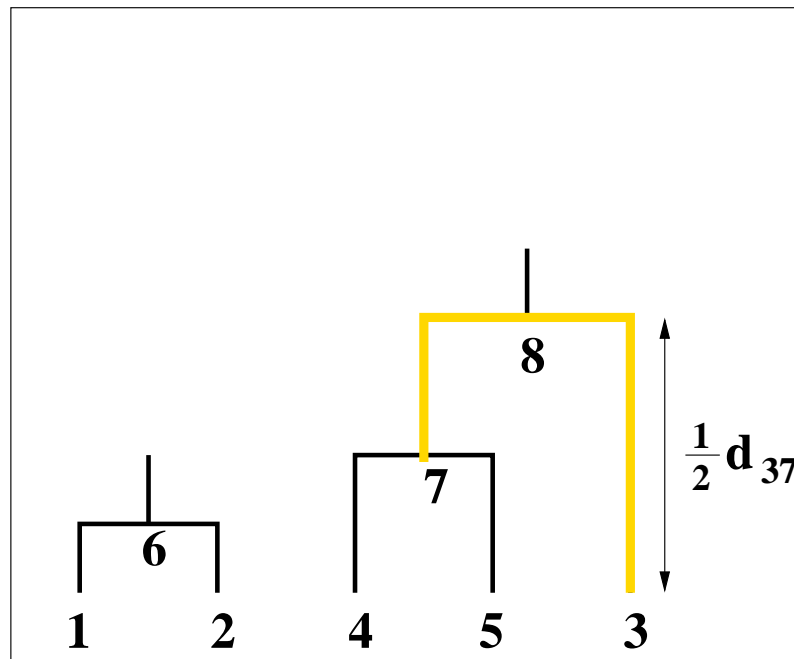
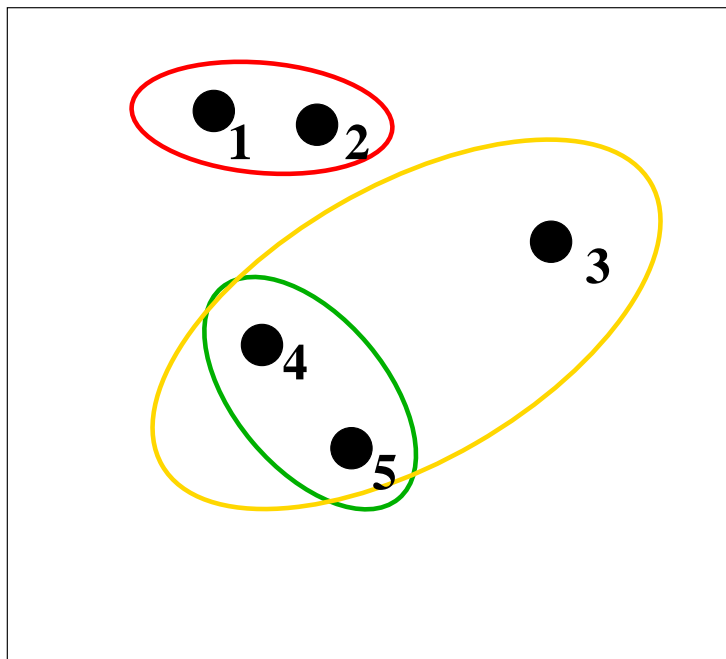

UPGMA: Analysis

- A metric on a set of objects O is given by the assignment of a real number $d(x,y)$ to every pair $x, y \in O$ where $d(x,y)$ has to fulfill the following requirements:

$$d(x, y) > 0 \quad \text{for } x \neq y, \quad d(x, y) = 0 \quad \text{for } x = y$$

$$d(x, y) = d(y, x)$$

$$d(x, y) \leq d(x, z) + d(z, y) \quad \forall x, y, z \quad (\text{triangle inequality})$$

- An ultrametric has to fulfill a restricted triangle inequality

$$d(x, y) \leq \max (d(x, z), d(y, z)).$$

- A **clocklike**, or **ultrametric** tree is a rooted tree, in which the total branch length from the root to any leaf is equal
→ **molecular clock** that ticks in a constant pace, and all the observed species are at an equal number of ticks from the root.

UPGMA: Analysis

- One can show: If the input data are ultrametric then UPGMA is **guaranteed to return the optimal solution**.
- For substantially **non-clocklike** trees, the algorithm might give seriously **misleading results**.

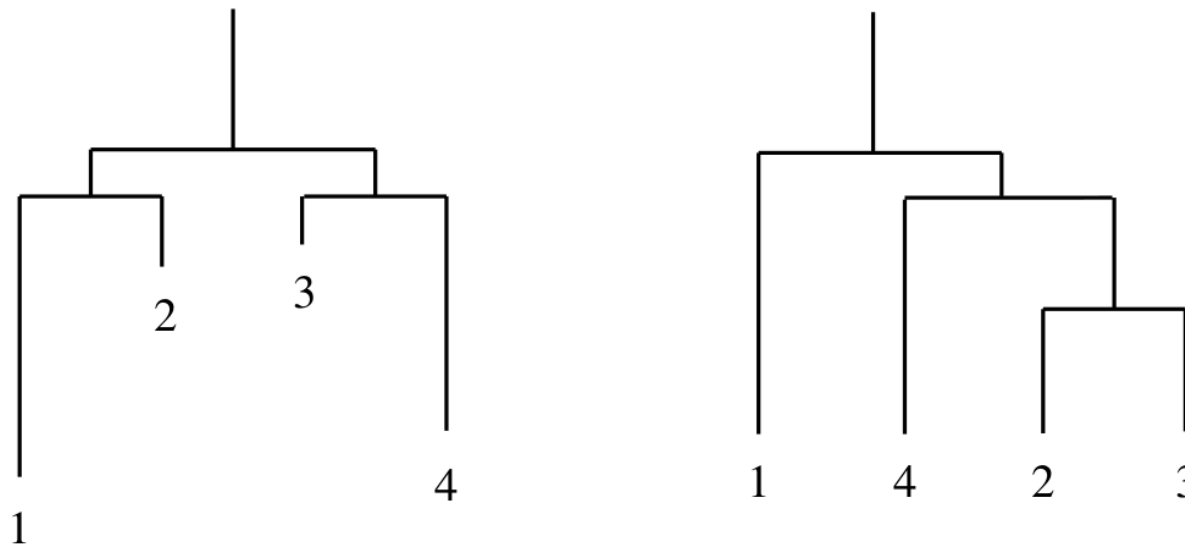

Figure 7.5 *A tree (left) that is reconstructed incorrectly by UPGMA (right).*

Additive trees

- **Ultrametric tree:**
 - $\#(\text{mutations}) \propto \text{temporal distance}(\text{node}, \text{ancestor})$,
 - mutations took place with the same rate in all paths.
- But it's a fact, that the evolutionary clock is running **differently** for different species (and even for different regions in a sequence).
- Generalization: **additive trees** (i.e. trees built from additive distance matrices). Unrooted tree, reflection of our ignorance as to where the common ancestor lies.
- All nodes (except for the leaves) have degree three
 \rightsquigarrow **unrooted binary tree**. More general, but undirected.

Additive distance matrix

Distance matrix D is additive iff there exists a tree T with $d_{ij}^T = d_{ij}$
 $\rightsquigarrow SSQ(T) = \sum_{i=1}^n \sum_{j \neq i} (d_{ij} - d_{ij}^T)^2 = 0.$

Every ultrametric is additive, but the converse is not true.

Simple test for additivity?

Four point condition: For every set of four leaves i, j, k and l , two of the distances $d_{ij} + d_{kl}$, $d_{ik} + d_{jl}$ and $d_{il} + d_{jk}$ must be equal and larger than the third. For instance

$$d(i, j) + d(k, l) \leq d(i, k) + d(j, l) = d(i, l) + d(j, k).$$

Generalizes the triangle inequality (take $k = l$).

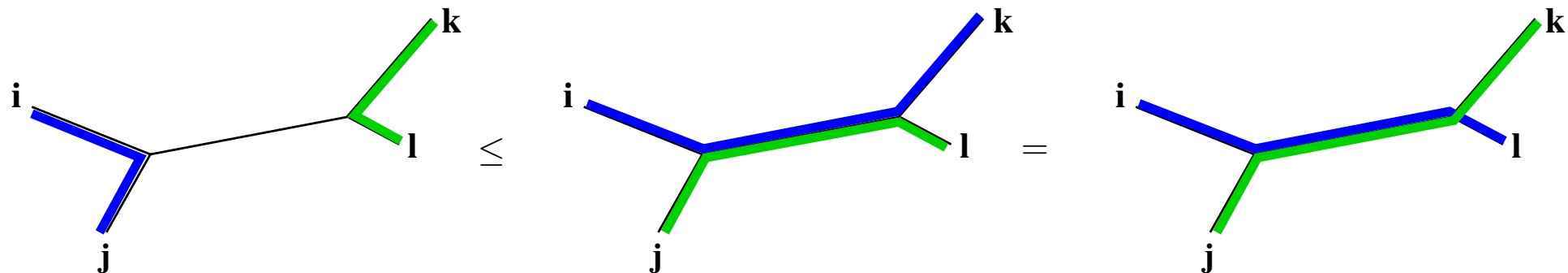

Neighbor Joining

- Neighbor-Joining approximates the least squares tree, assuming **additivity**, but **without resorting to the assumption of a molecular clock**.
- **Idea:** Find direct ancestor of two species, join them, iterate.
- **Distance computation:** Assume we join i and j with ancestor k → remove i, j from list of leaves → add k to list with distances to other leaves m defined as $d_{km} = \frac{1}{2}(d_{im} + d_{jm} - d_{ij})$.

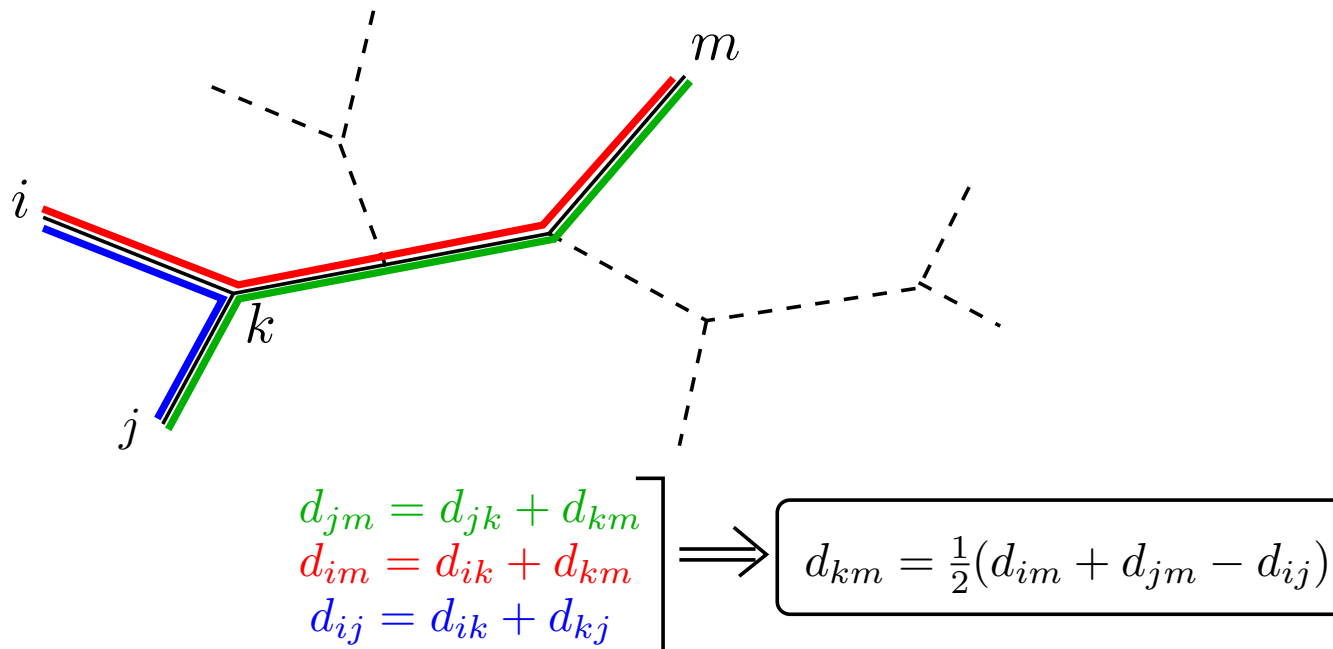

Correcting distances

Problem: it is not sufficient to pick simply the two closest leaves.

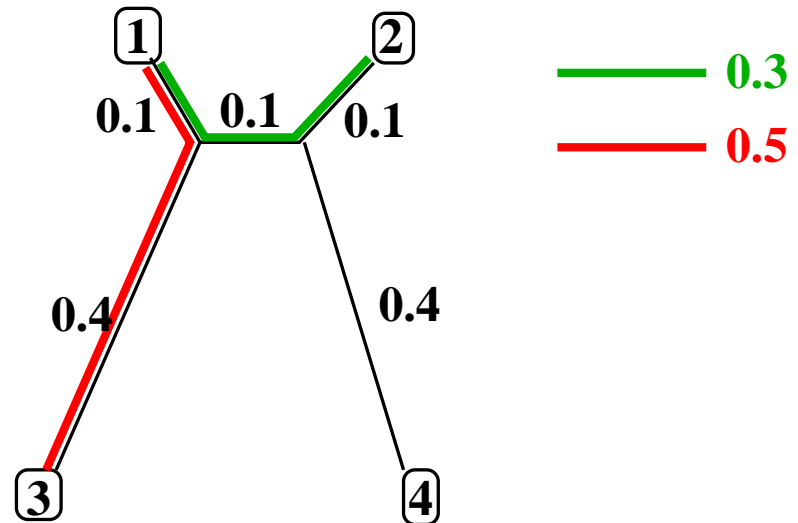

Solution: Join clusters that are not only close, but are also far from the rest. For node i , define average distance u_i to all other leaves:

$$u_i = \sum_{k \neq i} \frac{d_{ik}}{(n-2)}, \text{ and "correct" distances: } q_{ij} = d_{ij} - (u_i + u_j).$$

$$D = \begin{bmatrix} 0 & 0.3 & 0.5 & 0.6 \\ & 0 & 0.6 & 0.5 \\ & & 0 & 0.9 \\ & & & 0 \end{bmatrix}, \quad Q = \begin{bmatrix} * & -1.1 & -1.2 & -1.1 \\ & * & -1.1 & -1.2 \\ & & * & -1.1 \\ & & & * \end{bmatrix}$$

Neighbor Joining Theorem

(Studier & Keppler, Molecular Biology and Evolution 5:729-731, 1988): For a tree with additive lengths, q_{ij} minimal implies i, j are neighboring leaves.

We know how to compute the branch lengths from a new node k to all other nodes $m \neq (i, j)$.

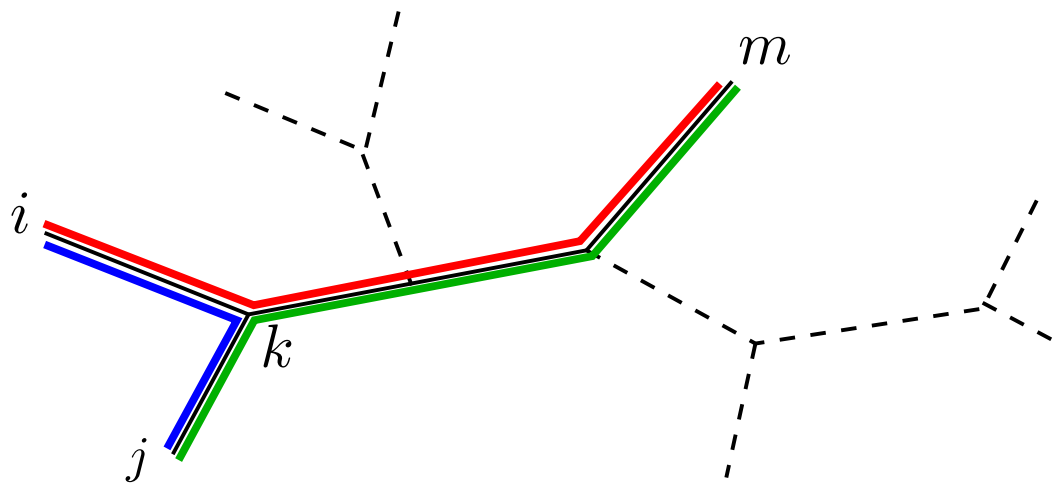

$$\begin{aligned} d_{jm} &= d_{jk} + d_{km} \\ d_{im} &= d_{ik} + d_{km} \\ d_{ij} &= d_{ik} + d_{kj} \end{aligned}$$

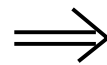

$$d_{km} = \frac{1}{2}(d_{im} + d_{jm} - d_{ij})$$

Neighbor-Joining: Distance Computation

What about i and j ? $d_{ik} = \frac{1}{2}(d_{ij} + d_{im} - d_{jm}), \forall m \neq (i, j)$.

If observed distances are indeed fully additive, we can pick any $m \neq (i, j)$. In practice, it might be better to average:

$$\begin{aligned}d_{ik} &= \frac{1}{2}(d_{ij} + d_{im} - d_{jm}), \forall m \neq (i, j) \Rightarrow \text{average over } m \Rightarrow \\&= \frac{1}{2} \cdot \frac{1}{n-2} \sum_{m \neq (i, j)} (d_{ij} + d_{im} - d_{jm}) \\&= \frac{1}{2}d_{ij} + \frac{1}{2} \cdot \frac{1}{n-2} \sum_{m \neq (i, j)} (\overbrace{q_{im} + u_i + u_m}^{d_{im}} - q_{jm} - u_j - u_m) \\&= \frac{1}{2}(d_{ij} + u_i - u_j) + \frac{1}{2} \cdot \frac{1}{n-2} \cdot \underbrace{\sum_{m \neq (i, j)} (q_{im} - q_{jm})}_{=0}\end{aligned}$$

Neighbor-Joining algorithm: Initialization:

1. Initialize n clusters with the given species, one species per cluster.
2. Set the size of each cluster to 1: $n_i \leftarrow 1$.
3. In the output tree T , assign a leaf for each species.

Iteration:

1. For each species, compute $u_i = \sum_{k \neq i} \frac{d_{ik}}{(n-2)}$
2. Choose the i and j for which $d_{ij} - u_i - u_j$ is smallest.
3. Join clusters i and j to new cluster, with corresponding node k and set

$$d_{km} = \frac{1}{2}(d_{im} + d_{jm} - d_{ij}) \quad \forall m \neq (i, j) \in \text{Nodes}(T).$$

Calculate the branch lengths from i and j to the new node as:

$$d_{ik} = \frac{1}{2}(d_{ij} + u_i - u_j) \quad , \quad d_{jk} = \frac{1}{2}(d_{ij} + u_j - u_i).$$

4. Delete clusters i and j from T and add k .
5. If more than two nodes remain, go back to 1. Otherwise, connect the two remaining nodes by a branch of length d_{ij} .

Reconstructing Trees from Non-additive Matrices

- Q: What if the distance matrix is **not** additive?
- A: We could still run NJ!
- Q: But can **anything** be said about the resulting tree?
- A: Not really. Resulting tree topology could even vary according to way **ties are resolved** on the way.

Almost Additive Distance Matrices

A distance matrix D' is called “**almost additive**” if there exists an additive matrix D (with corresponding tree T) such that

$$|D - D'|_{\infty} = \max_{i,j} \{|d_{i,j} - d'_{i,j}|\} \leq \min_e \{l(e)/4\},$$

where e is an edge in the tree T (corresponding to the additive matrix D) with length $l(e)$.

Theorem: If D' is almost additive with respect to a tree T , then the output of NJ is a tree T' with the **same topology** as T .

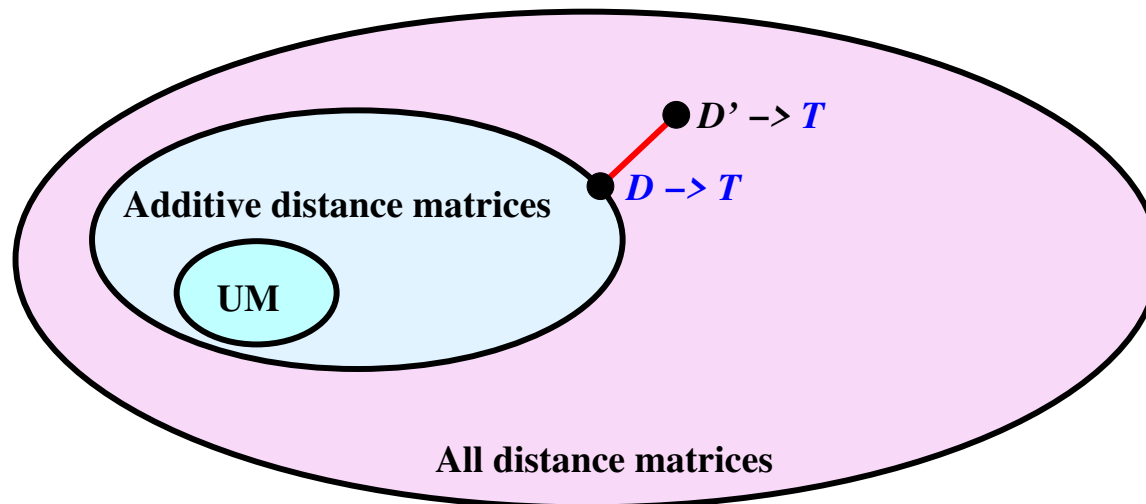

Character Based Methods

Problem: Optimal Phylogenetic Tree. **INPUT:**

- A set of n **species**.
- A set of m **characters** pertaining to all of these species,
- For each species, the **values** of each of the characters.
- **Notation:** $n \times m$ matrix M , where $M_{i,j}$ represents the value of the j -th character of the i -th species. The **value** of each character is taken from a known alphabet Σ .

Question: What is the fully labeled phylogenetic tree that best explains the data, i.e., maximizes some target function.

Limiting assumptions: (probably not exactly correct in practice)

- Characters are **mutually independent** (\rightarrow change in one character has no effect on the distribution of another character).
- After two species diverged in the tree, they **continue to evolve independently**.

Character-based Methods: Parsimony

- Intuitive **score** for tree: **number of changes** along edges.
- Minimizing this score is called **parsimony**.

Notation: $V(T)$: **vertices** of a tree, $E(T)$: **edges**.

v_j : **value** of j -th character at vertex $v \in V(T)$.

Given a phylogenetic tree T , its **parsimony score** is defined as

$$S(T) = \sum_{(v,u) \in E(T)} |\{j : v_j \neq u_j\}|$$

That is - the total number of times the **value of some character changes** along some edge.

Most parsimonious 5-species phylogeny for 6 characters:

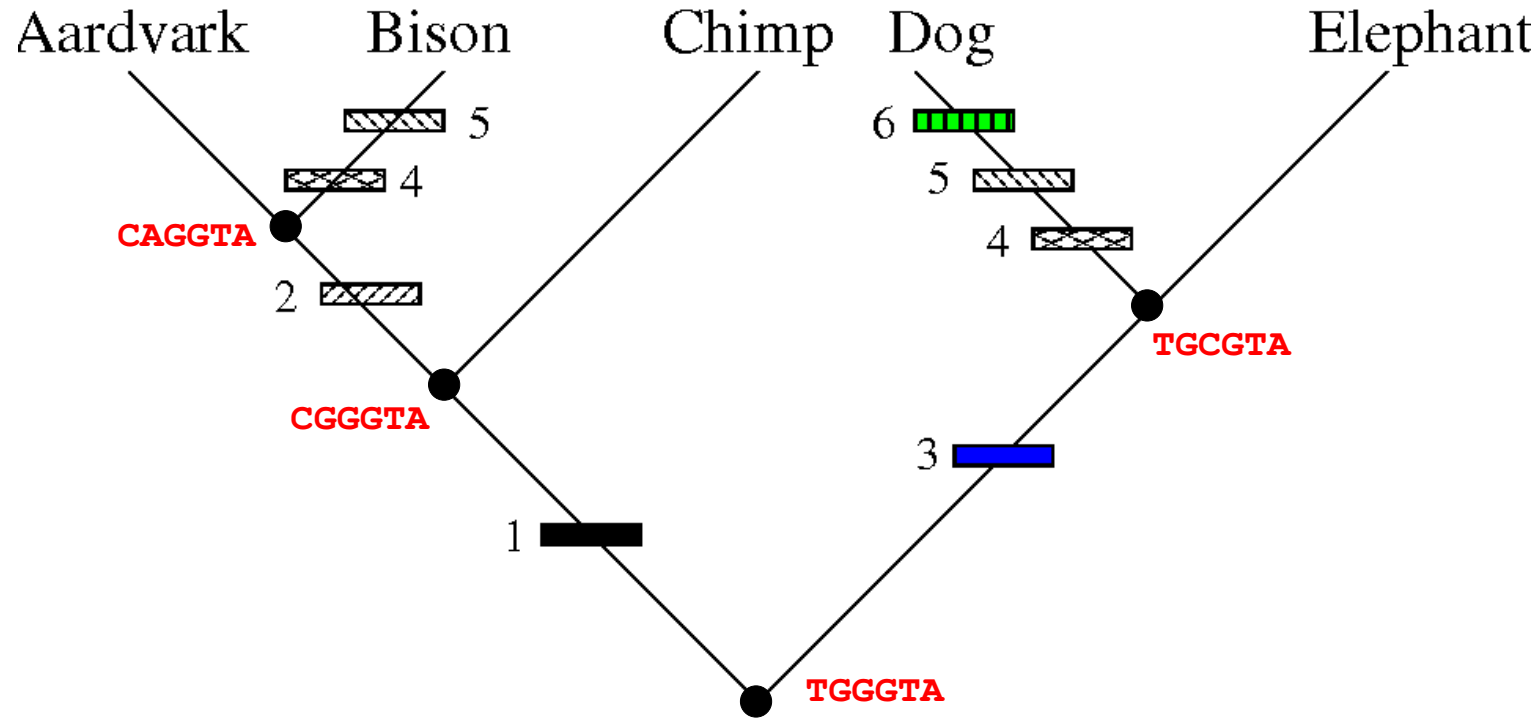

Adapted from Figure 8.8 in R. Shamir, Orly Stettiner, R. Gabor: Algorithms for Molecular Biology 8.1 Preface:
Phylogenetics and Phylogenetic Trees

	1	2	3	4	5	6
Aardvark	C	A	G	G	T	A
Bison	C	A	G	A	C	A
Chimp	C	G	G	G	T	A
Dog	T	G	C	A	C	T
Elephant	T	G	C	G	T	A

Weighted Small Parsimony

- Cost of a change is not necessarily constant:
 C_{ij}^c = cost of the character c changing from state i to state j .
- **Goal:** minimize the total cost of the tree given the topology and the leaf labels.

Problem: Weighted Small Parsimony.

INPUT: The topology of a rooted phylogenetic tree with leaves having labels in Σ . The costs C_{ij}^c for $i, j \in \Sigma$. There are k possible character values, $|\Sigma| = k$.

QUESTION:

1. What is the minimum possible cost for this topology?
2. What is the optimal labeling of the internal nodes?

Recall: Tree traversals

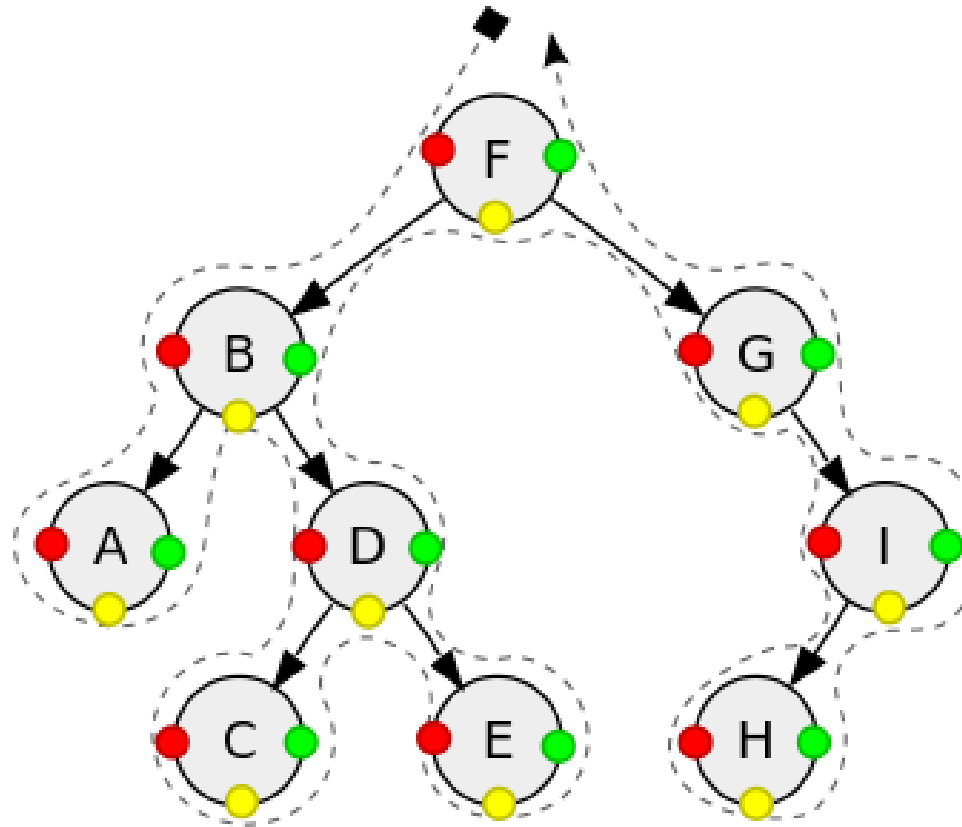

Public Domain, <https://commons.wikimedia.org/w/index.php?curid=83230146>

Depth-first traversal of an example tree:

pre-order (red): F, B, A, D, C, E, G, I, H

in-order (yellow): A, B, C, D, E, F, G, H, I

post-order (green): A, C, E, D, B, H, I, G, F.

Sankoff's algorithm

Step 1: for each node v and each state t compute quantity $S_t^c(v)$: minimum cost of the subtree whose root is v , assuming that the character value at v is t , i.e. ($v_c = t$). **In postorder:** for each leaf v :

$$S_t^c(v) = \begin{cases} 0 & v_c = t \\ \infty & \text{otherwise} \end{cases}$$

For an internal node v , with subnodes u and w :

$$S_t^c(v) = \min_i \{C_{ti}^c + S_i^c(u)\} + \min_j \{C_{tj}^c + S_j^c(w)\}$$

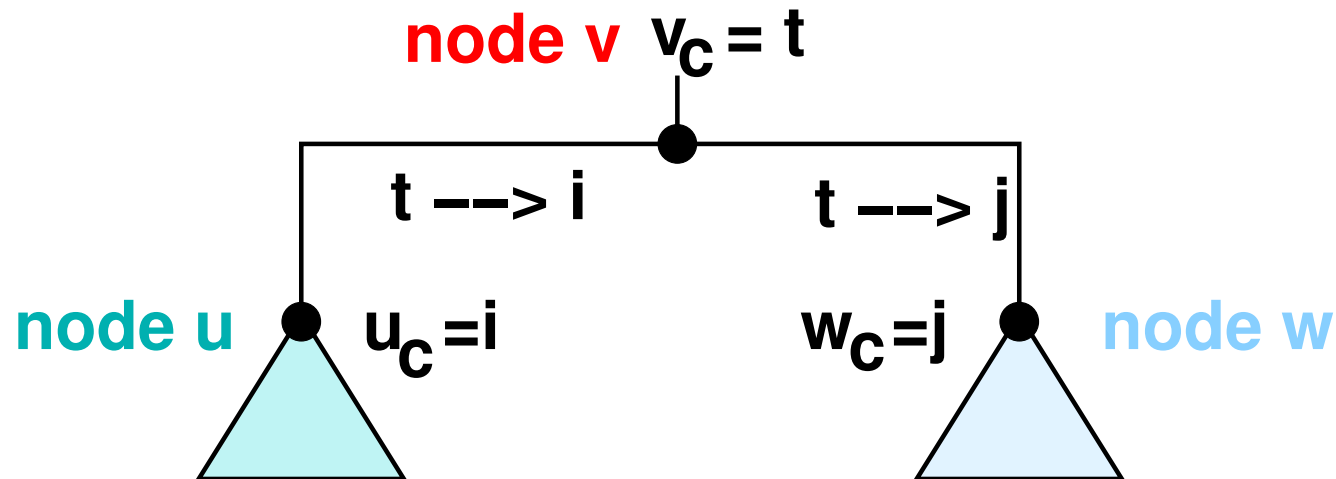

Sankoff's algorithm

For m characters, minimum total cost of a tree with root r :

$$S(T) = \sum_{c=1}^m \min_t S_t^c(r)$$

Step 2: Based on $S_t^c(v)$, determine the **optimal values for each character** in internal nodes. **Preorder:** For the root node r , choose character value $r_c = \arg \min_t S_t^c(r)$.

For any other node v , with parent node u ,

$$v_c = \arg \min_t (C_{uct}^c + S_t^c(v))$$

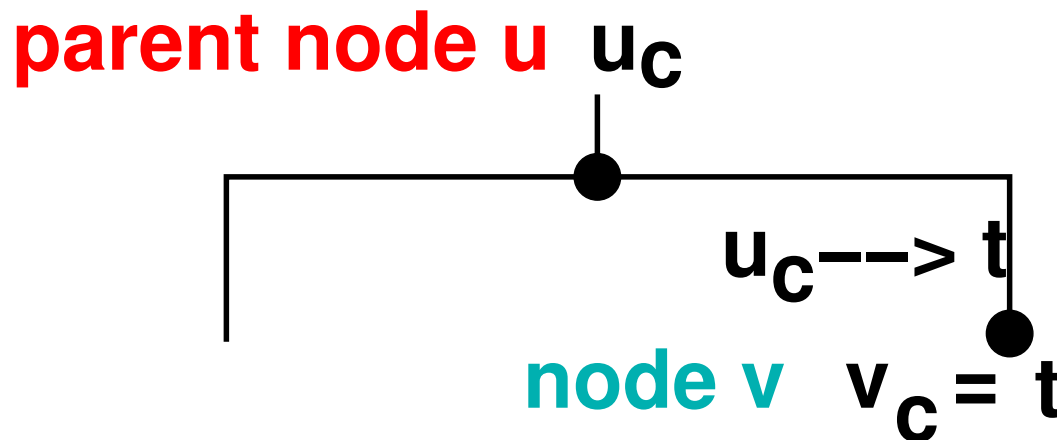

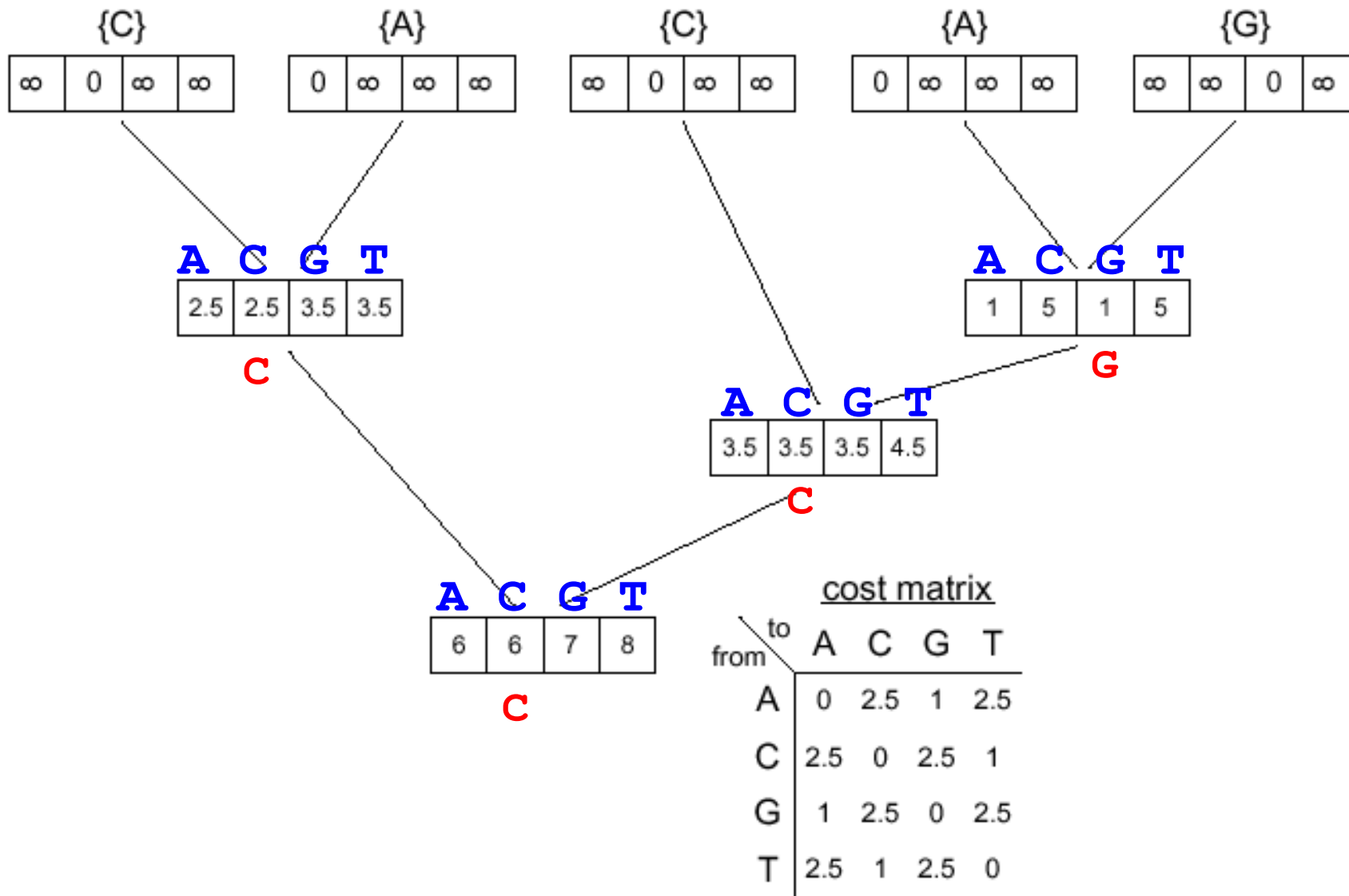

Adapted from Figure 8.10 in R. Shamir, Orly Stettiner, R. Gabor: Algorithms for Molecular Biology 8.1 Preface: Phylogenetics and Phylogenetic Trees

Large Parsimony

Final goal: find the optimal phylogeny, not just the optimal internal labeling of a given phylogeny.

Problem: Large Parsimony.

INPUT: A matrix M describing m characters of a set of n species,

QUESTION: What is the optimal phylogeny for these species, i.e., the one minimizing the parsimony score?

Remark: weighted and a non-weighted version, but difference is not essential. It can be shown that this **problem is NP-hard**. However, several approximation heuristics exist.

Branch and Bound

- **Branch-and-Bound** (B&B) deals with optimization problems over a **search space** that can be presented as the **leaves of a tree**.
- First used for parsimony by (Hendy and Penny, 1982).
- Works when the **search tree is monotonous**: the score of each node in the search tree is at least as bad as that of any of its ancestors.
- B&B is **guaranteed to find the optimal solution**, but its complexity in the worst case is as high as that of exhaustive search.
- Basic version: Tree is traversed in some order, cost of the best leaf found so far is kept as a bound C' . When a node is reached whose cost is $C > C'$, the tree is **pruned at that node**.

Branch and Bound for Parsimony

- **Parsimony:** present the search-space as a search tree:
 - k -th level of search tree: nodes represent all possible phylogenetic trees with k leaves for the first k species,
 - Children of such a node: all phylogenetic trees created by adding the $(k + 1)$ -th species.
- Search tree is **monotonous**, since adding a node to a given tree can **never reduce** its parsimony score.
- **Does not lower worst-case time complexity.** However, in real-life test cases it proved to speed up the search considerably.
- Plausible strategy: Start with distance-based approach. Neighbor joining \rightsquigarrow initial topology T' \rightsquigarrow compute its parsimony cost C' \rightsquigarrow use this as initial bound.

Branch and Bound for Parsimony (cont'd)

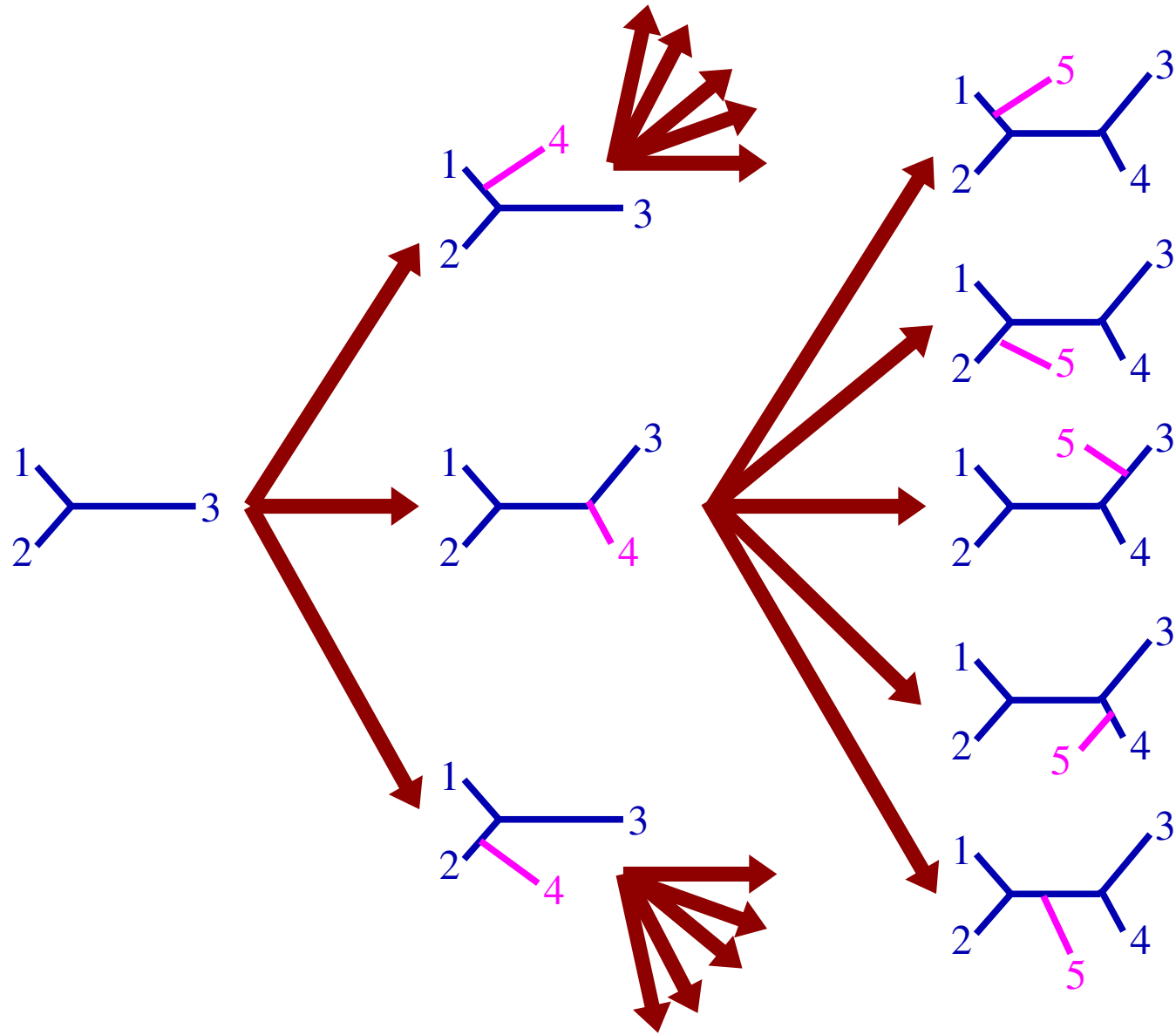

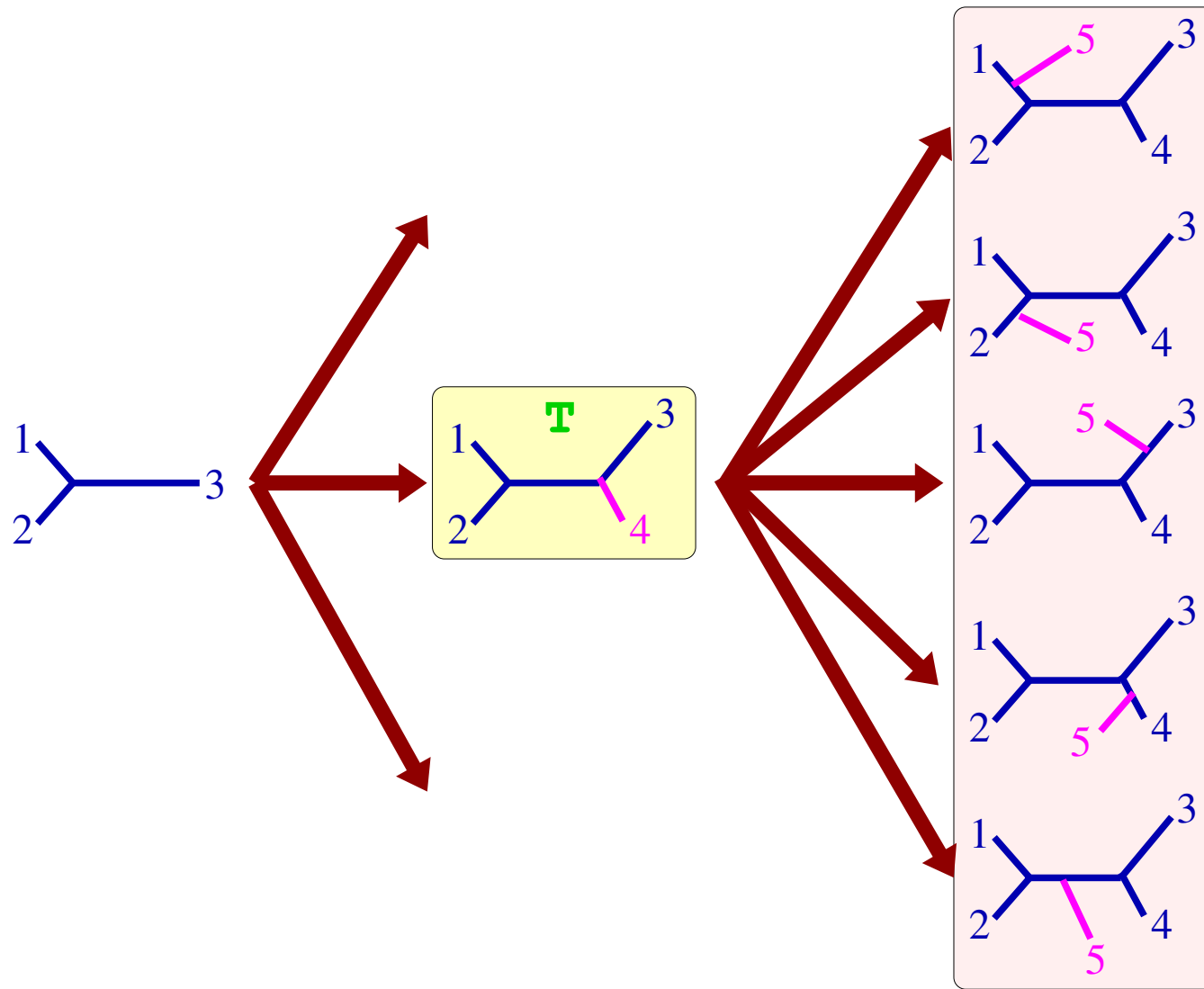

If partial tree **T** has $cost = C$,
 & the best complete tree seen has $cost = C' < C$
Then prune expansions of **T**

Maximum Likelihood Methods

- Given a tree, we often wish to have a statistical measure of how well it describes our data.
- **Likelihood function:** $P(\text{Data}|\text{Parametrized model})$, treated as a function of the parameters.
- In our case, the model is a phylogenetic tree, parametrized by its topology T and the set of edge lengths t , representing biological time, or genetic distance, between two connected nodes.
- **Problem 1:** For a set of species with observed values M , what is the likelihood score of a given tree (T, t) ?
- **Problem 2 (Maximum likelihood inference):** What is the tree that maximizes $P(M|T, t)$, i.e. best explains the observations?

Computing the Likelihood of a Tree

- **Labels** are the sets of m character values associated with each species, or node in the tree.
- A **reconstruction** is a full labeling of the tree's internal nodes.
- A **branch length** t_{vu} measures the biological time, or genetic distance, between the species associated with these nodes.
- **Assumptions:**
 - characters are pairwise independent,
 - branching is a **Markov process**: probability of a node having a given label is a function only of the **state of its parent node and the branch length t between them**.
 - character frequencies are fixed throughout the evolutionary history, and that they are given as $P(x)$.

The Maximum Likelihood Problem

Problem: Likelihood of a Tree.

INPUT:

- A matrix M describing a set of m characters for each one of n given species.
- A tree with given topology T , with the above species as the leaves and with known branch lengths t_{vu} .

QUESTION: Calculate the likelihood L of the tree, assuming the m characters are independent:

$$L = P(M|T, t) = \prod_{\text{character } j} P(M_j|T, t)$$

Likelihood of a tree

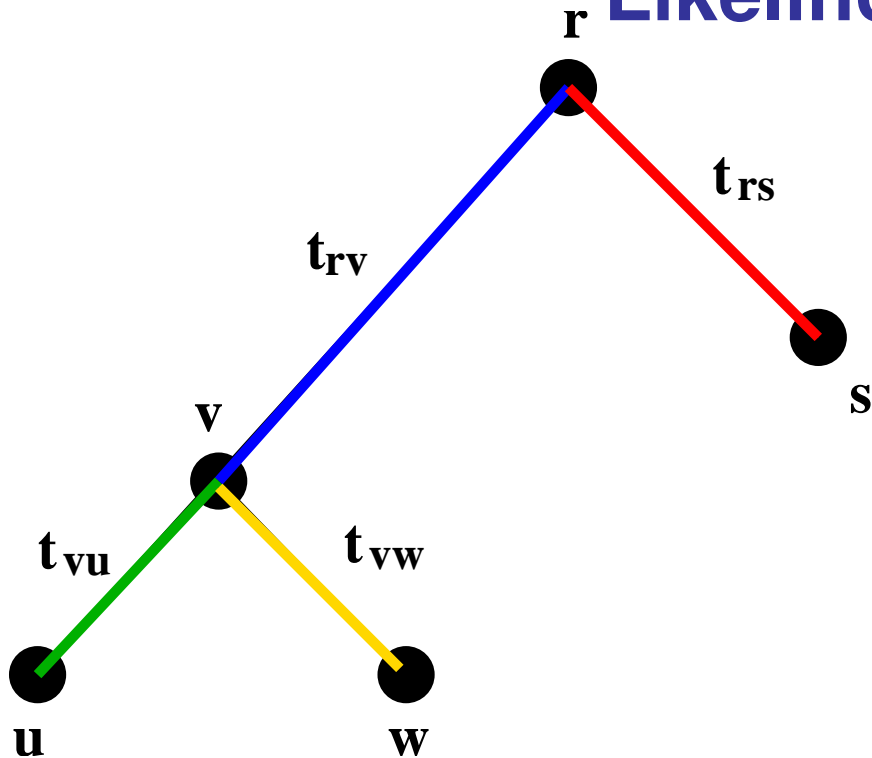

Labels of internal nodes are unknown \rightsquigarrow sum over all possible reconstructions (=labelings of internal nodes).

$$L = \sum_r \sum_v P(r) \cdot P_{r \rightarrow s}(t_{rs}) \cdot P_{r \rightarrow v}(t_{rv}) \cdot P_{v \rightarrow u}(t_{vu}) \cdot P_{v \rightarrow w}(t_{vw})$$

Multiple independent characters:

$$L = \prod_{\text{character } j} P(M_j | T, t) = \prod_{\text{character } j} \left\{ \sum_{\text{reconstruction } R} P(r) \cdot \prod_{\text{edges}} P_{u \rightarrow v}(t_{uv}) \right\}$$

Computing the Likelihood

Dynamic-programming algorithm [Felsenstein, Evolutionary trees from DNA sequences: a maximum likelihood approach. J. Mol. Evol. (1981)17:386-376].

Notation:

Likelihood of v 's subtree, given that v has the label x at position j :

$$C_j(x, v) = P(\text{subtree whose root is } v \mid v_j = x)$$

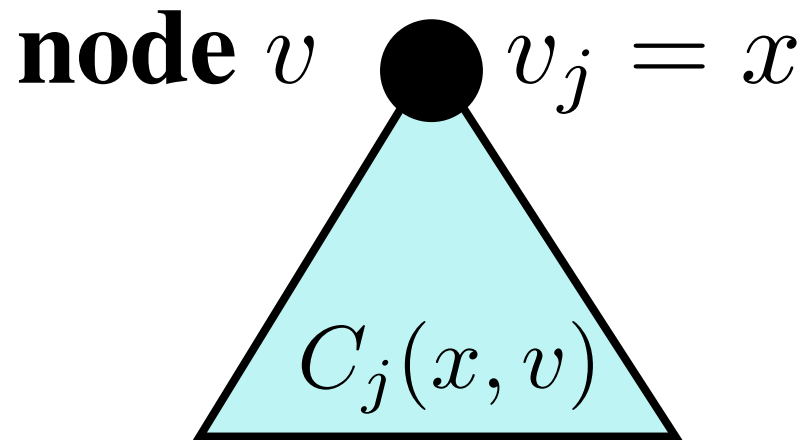

Initialization: For each leaf v and label x :

$$C_j(x, v) = \begin{cases} 1 & \text{if } v_j = x \\ 0 & \text{otherwise} \end{cases}$$

Recursion: Traverse the tree in postorder. For an internal node v with children u and w , compute for each possible label x :

$$C_j(x, v) = \left[\sum_y C_j(y, u) \cdot P_{x \rightarrow y}(t_{vu}) \right] \cdot \left[\sum_y C_j(y, w) \cdot P_{x \rightarrow y}(t_{vw}) \right].$$

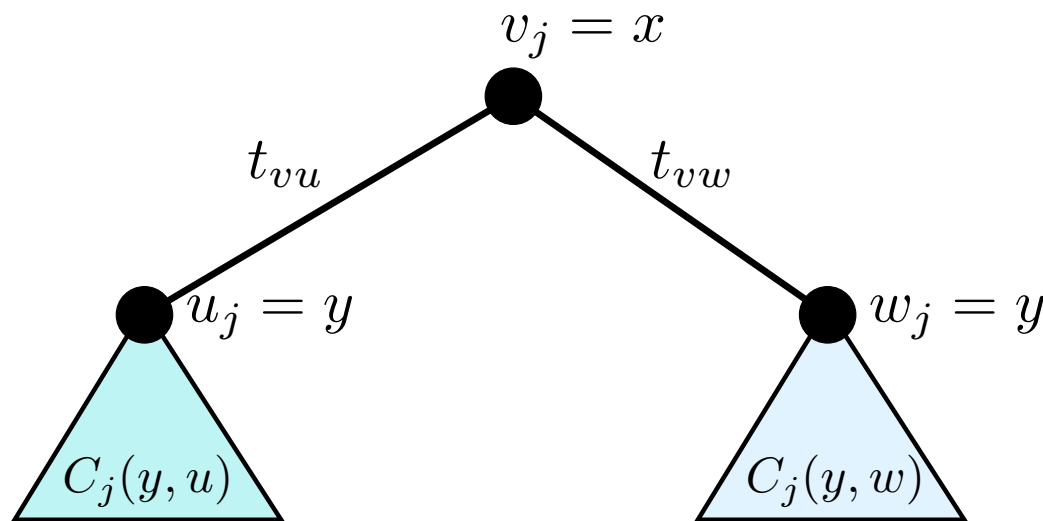

Final solution: $L = \prod_{j=1}^m \left[\sum_x C_j(x, \text{root}) \cdot P(x) \right].$

Maximizing the Likelihood

- **Optimal Branch Lengths.** Given the topology, find the optimal branch length (optimality = maximum likelihood).

No analytical solution known. Use numerical methods such as conjugate gradients, based on the derivatives $\frac{\partial}{\partial t_{vw}} P_{x \rightarrow y}(t_{vw})$.

- **Optimal topology.** Even harder problem.

EM-like methods have been proposed:

Iteratively optimize topology and branch lengths, e.g. “Structural EM” [Friedman et al, J Comput Biol. 2002; 9(2):331-353].

Bayesian approaches

- Instead of solving for the maximum likelihood tree, investigate the **distribution of trees, given the observations**:
↪ **Posterior distribution of trees.**

M : observed characters. T : topology. t : edge lengths.

$$\underbrace{P(T, t|M)}_{\text{posterior}} = \frac{\overbrace{P(M|T, t)}^{\text{likelihood}}}{P(M)} \cdot \underbrace{P(T, t)}_{\text{prior}}.$$

- Typically, we do not have the posterior in analytic form, but we might be able to **draw samples from the posterior.**
- Law of large numbers: Frequency of a **property in the sample** will converge to the posterior probability.
- Example: If a particular tree topology is present in some fraction r of the samples, then r is an estimate of the posterior probability of this topology.

The Metropolis Method

- A method for **drawing samples from a posterior distribution.**
- **Proposal mechanism:** A procedure f that generates a tree (\tilde{T}, \tilde{t}) randomly based on the current tree (T, t) , **by sampling from a proposal distribution.**
- Define posteriors $P_1 = P(T, t|M)$ and $P_2 = P(\tilde{T}, \tilde{t}|M)$.
- **Step 1:** Build an **initial random tree** (T, t) and calculate P_1 .
- **Step 2: Propose new tree** $f(T, t) = (\tilde{T}, \tilde{t})$ and calculate P_2 .
- **Step 3: Accept** new tree if $P_2 > P_1$.
If $P_2 < P_1$, accept only with probability P_2/P_1 .
If accepted, new sample is (\tilde{T}, \tilde{t}) , otherwise sample is (T, t) .
- **Step 4:** Go to Step 2.

The Metropolis Method (cont'd)

- Note: only the rate P_2/P_1 must be calculated
 \rightsquigarrow **exponentially large sum** $P(M) = \sum_{\text{all trees } (T,t)} P(M, T, t)$
in Bayes formula **is avoided!**
- Guaranteed to **asymptotically sample correctly from the posterior distribution**, if the proposal distribution is symmetric:
Probability of proposing (\tilde{T}, \tilde{t}) from (T, t) is the same as proposing (T, t) from (\tilde{T}, \tilde{t}) . Can be relaxed \rightsquigarrow **Metropolis-Hastings.**
- **Crucial point: find suitable proposal distribution for trees.**
- **Exploration-exploitation trade-off:**
 - If proposed tree is merely sampled randomly, the posterior probabilities will be low \rightarrow low acceptance rate.
 - If proposed tree is too close to the current tree, many steps will be needed to explore the space of trees.

A Proposal Distribution for Trees

- **(Mau et al., 1996): Traversal profile:**
Tree can be reconstructed from profile, but allowing more **convenient manipulations of the topology.**
- Node is placed at height
 h = sum of the edge lengths from root to that node.
- Nodes are **regularly spaced horizontally**,
in the order given by an **in-order traversal of the tree.**
- For a node k , all left children have numbers $< k$,
and all right children $> k$.
- **Proposal procedure:**
Randomly shifting the positions of nodes up and down.
- Relative heights of nodes switched \rightsquigarrow **new topology produced.**
- Additional proposal mechanism reorders the leaves.

A Proposal Distribution for Trees

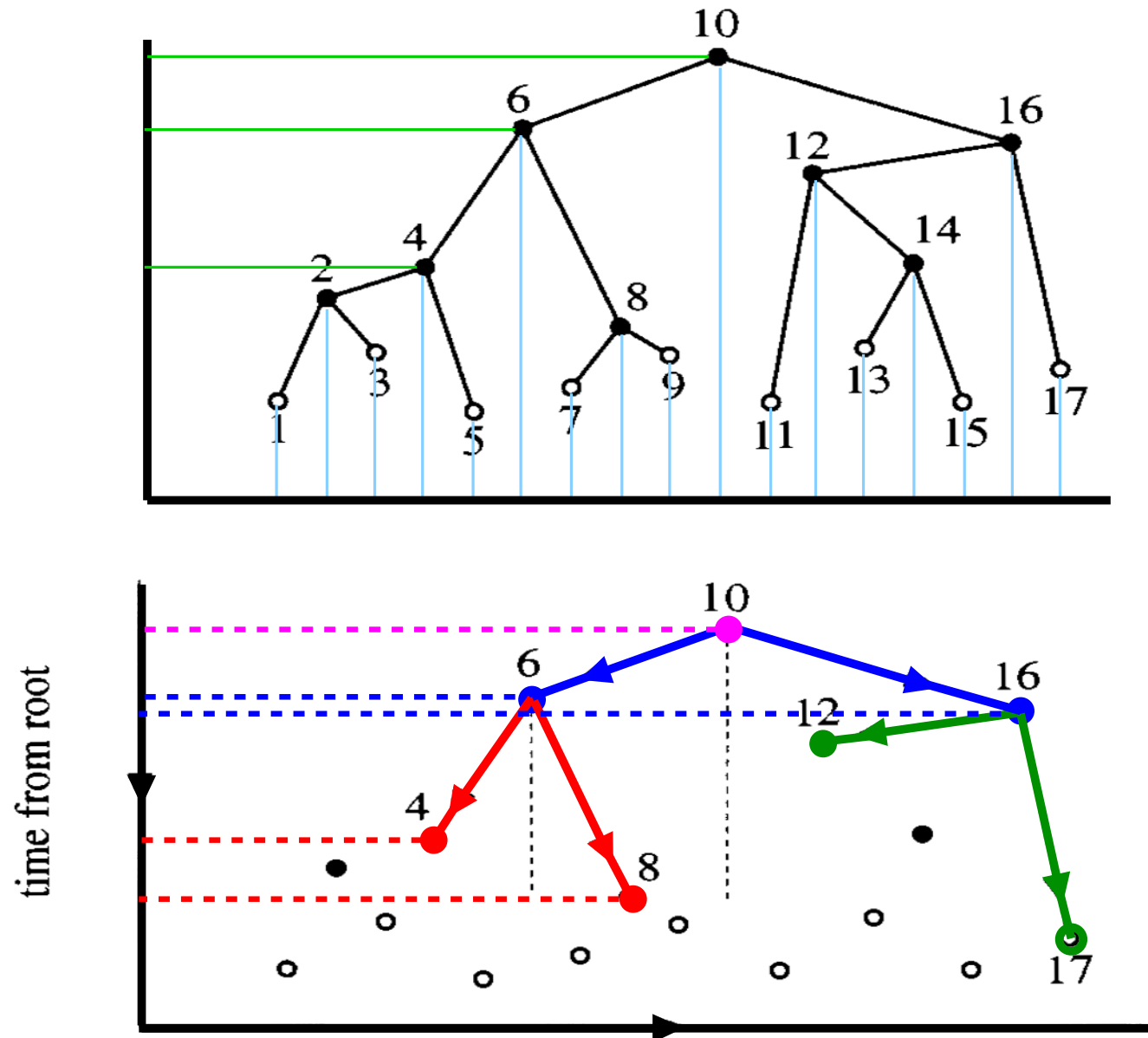

Above: an example of a tree with its nodes numbered in the order of the traversal profile. Below: Reconstruction of the tree from the traversal profile.

Adapted from Durbin et al., Cambridge University Press. <https://doi.org/10.1017/CBO9780511790492.004>

A Proposal Distribution for Trees (cont'd)

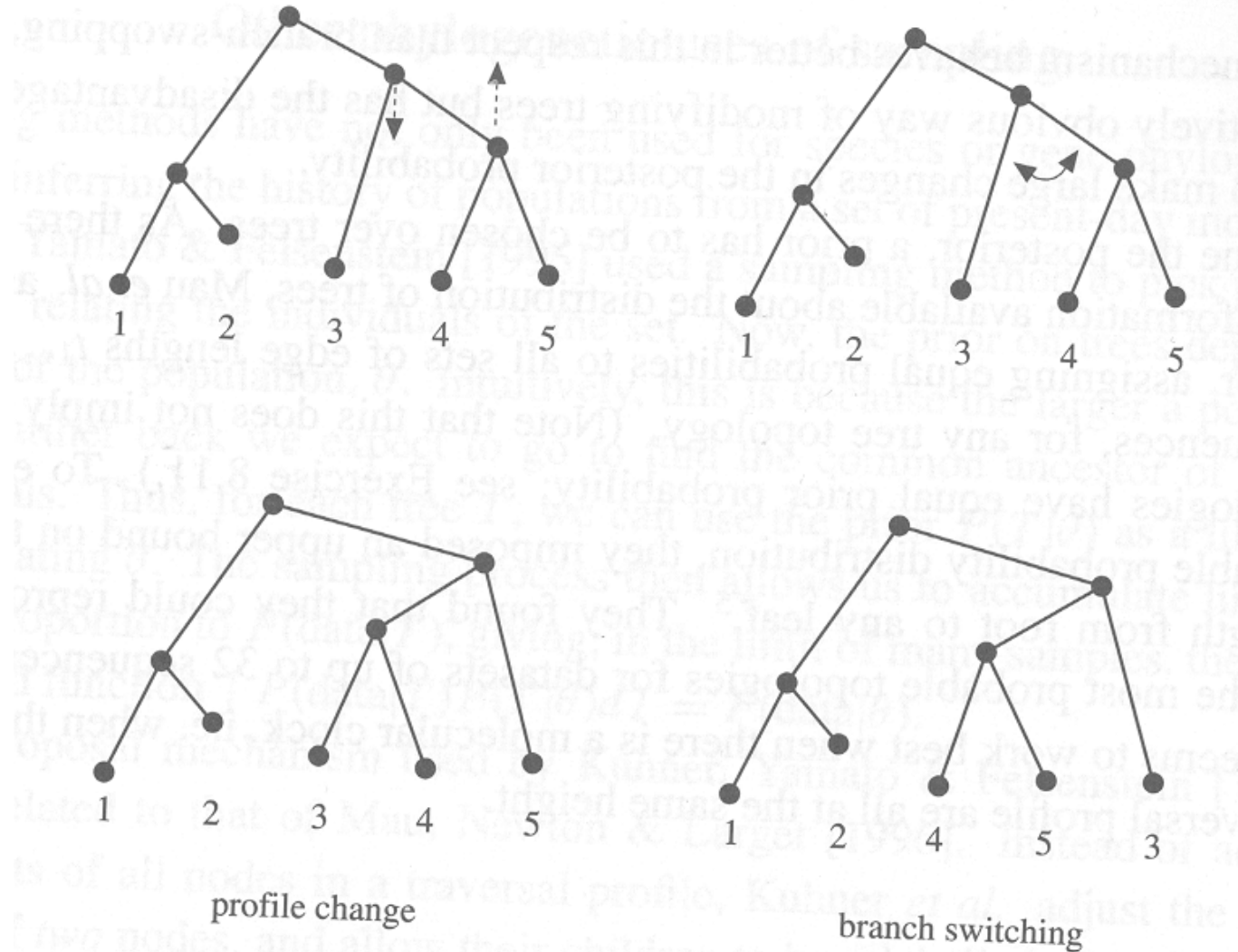

Durbin et al., Cambridge University Press. <https://doi.org/10.1017/CBO9780511790492.004>